

Yanmar type 3JH4E

The Powerful Gem

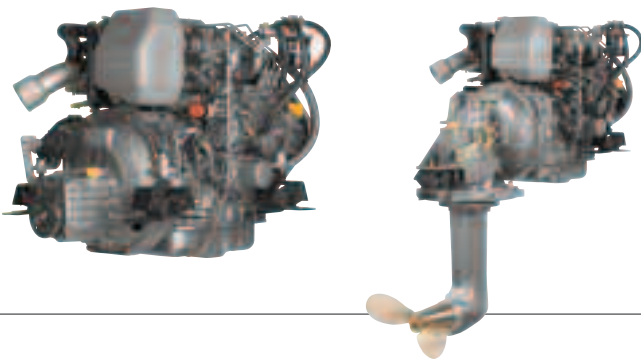

Configuration	4-stroke, vertical, water cooled diesel engine
Maximum output at crankshaft	* 29.4 kW (40 hp) / 3000 rpm ** 28.7 kW (39 hp) / 3000 rpm
Continuous rating output at crankshaft	26.7 kW (36.3 hp) / 2907 rpm
Displacement	1.640 L (100 cu in)
Bore x stroke	88 mm x 90 mm (3.46 in x 3.54 in)
Cylinders	3
Combustion system	Direct injection
Aspiration	Natural aspiration
Starting system	Electric starting 12 V - 1.4 kW
Alternator	12 V - 60 A (80 A optional)
Cooling system	Fresh water cooling by centrifugal fresh water pump and rubber impeller sea water pump
Lubrication system	Enclosed, forced lubricating system
Direction of rotation (crankshaft)	Counter clockwise viewed from stern
Dry weight without gear	173 kg (381 lbs)
Environmental	BSO II, SAV, EPA II, EMC compliant and will meet the 2003/44/EC emission requirements
Engine mounting	Rubber type flexible mounting

NOTE: Fuel condition: Density at 15°C = 0.842 g/cm³; 1 hp = 0.7355 kW
 * Fuel temperature 25°C at the inlet of the fuel injection pump (ISO 3046-1)
 ** Fuel temperature 40°C at the inlet of the fuel injection pump (ISO 8665)

Dimensions (For detailed line-drawings, please refer to our web-site: www.yanmarmarine.com)

Front view

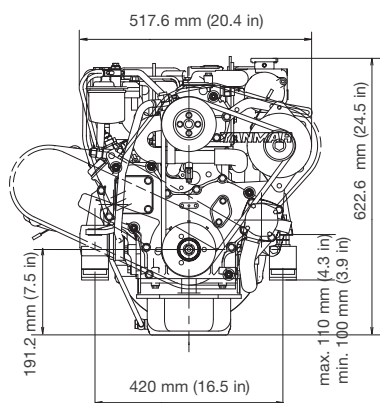

Right side view

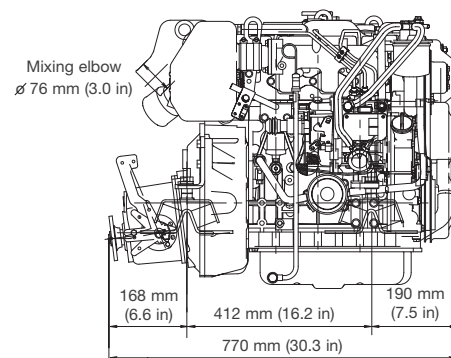

3JH4E w/ KM35A marine gear

Performance Curves (Output is according ISO 8665 - Output includes +/- 3% tolerance)

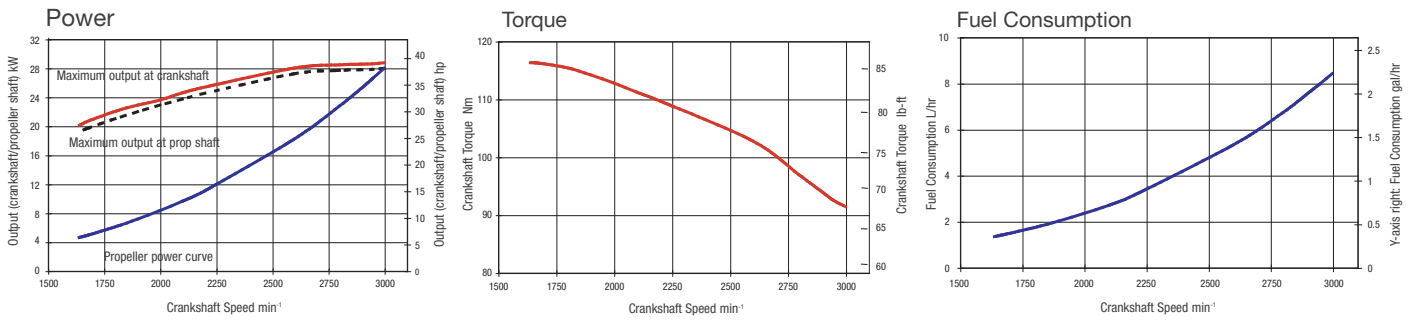

Marine Gears/Drive

Model	KM35P		KM35A (down angle: 7)		Saildrive (SD50)
Type	Mechanical cone clutch		Mechanical cone clutch		Mechanical cone clutch
Dry weight	12 kg (27 lbs)		13 kg (29 lbs)		40 kg (88 lbs)
Reduction ratio (fwd/asn)	2.36/3.16	2.61/3.16	2.33/3.04	2.64/3.04	2.32/2.32
Propeller speed(fwd/asn)	1231/921	1114/921	1246/955	1103/955	1253/1253
Direction of rotation (propeller shaft - fwd)	Clockwise viewed from stern		Counter clockwise viewed from stern		Clockwise & counter clockwise viewed from stern
Dry weight engine and gear/drive	185 kg (408 lbs)		186 kg (410 lbs)		213 kg (470 lbs)
Length engine and gear/drive	777 mm (31 in)		776 mm (31 in)		973 mm (38 in)

Instrument Panels

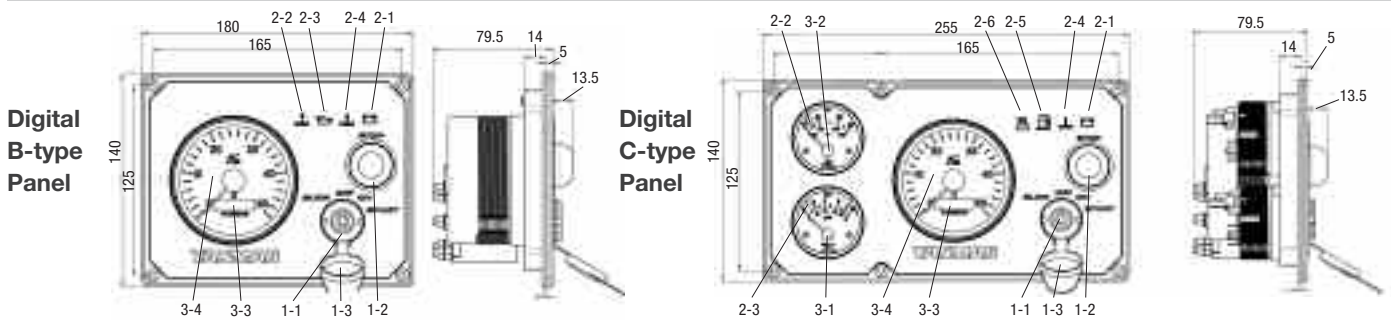

Function	Type of instrument panel	
	Digital B-type Panel	Digital C-type Panel
① Switch unit		
1-1 Key switch for GLOW/OFF/ON/START (4-position switch)	O	O
1-2 Push button switch for engine stop	O	O
1-3 Moisture cap for key switch	O	O
② Alarm lamp unit		
2-1 Battery low charge alarm	O	O
2-2 Coolant high temperature alarm	O	O
2-3 Lubricating oil low pressure	O	O
2-4 Water in sail drive seal alarm	O	O
2-5 Water in fuel filter alarm	X	O*
2-6 Sea water insufficient flow alarm	X	O*
③ Meters		
3-1 Lubricating oil pressure meter	X	O
3-2 Coolant temperature meter	X	O
3-3 Hour meter	O	O
3-4 Tachometer	O	O
④ Audible alarm buzzer	O	O

Note: O = Equipped on panel X = Not equipped on panel *function not available for 3JH4E natural aspiration engines

Accessories

Standard Package

- Set of flexible mounting
- Exhaust/water mixing elbow (L-type)
- V-belt cover
- Expansion tank for fresh water cooling system
- Alternator 12 V - 60 A
- Electric stop solenoid

Optional

- Additional Digital B-type instrument panel
- Additional Digital C-type instrument panel
- Primary 80 A alternator or second 60/80 A alternator
- Alternator bracket and cover for second alternator
- Exhaust/water mixing elbow, U-type (high riser)
- Various extension wire harnesses
- Various couplings (straights, tapers, slits)

Texts and illustrations are not binding. Yanmar Marine reserves the right to introduce adaptations without prior notification.